



# POWERSPORTS BATTERY Maintenance-Free AGM Battery Series

## CT7B-BS 12V 6.5AH(10HR)



JIS  
D5302

### Specification

BATTERY TYPE NUMBER	VOLTAGE (V)	CAPACITY AH (10HR)	CCA @-18°C	MAXIMUM DIMENSIONS						WEIGHT			
				MILLIMETERS(±2 mm)			INCHES (±1/16 in)			BATTERY ONLY		INCLUDE ACID AND PACKAGE	
				L	W	H	L	W	H	Kg	Lbs	Kg	Lbs
CT7B-BS	12	6.5	95	151	66	92	5 15/16	2 9/16	3 5/8	2.04	4.49	2.77	6.10

### Dimension

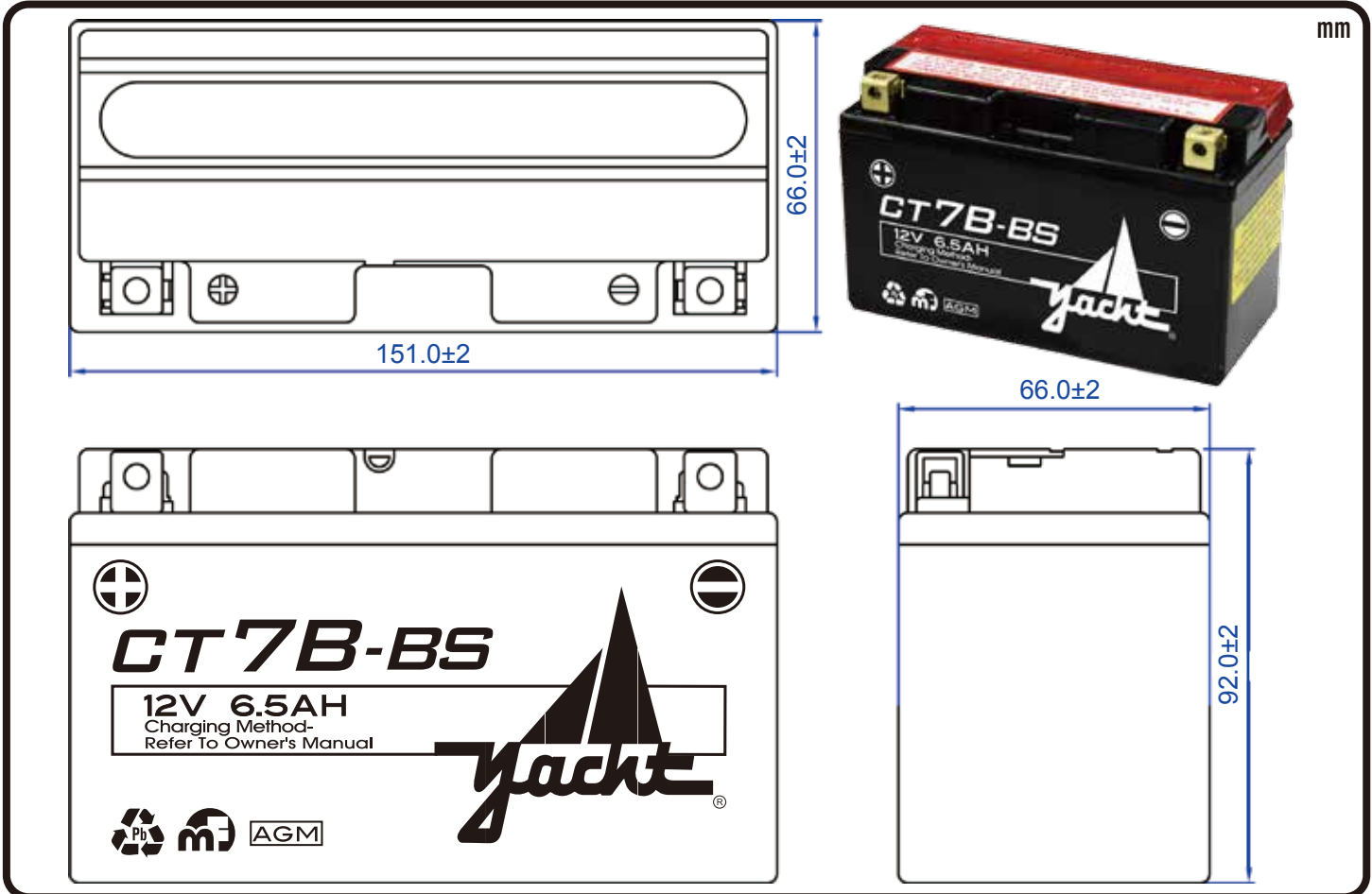

### Terminal Configuration

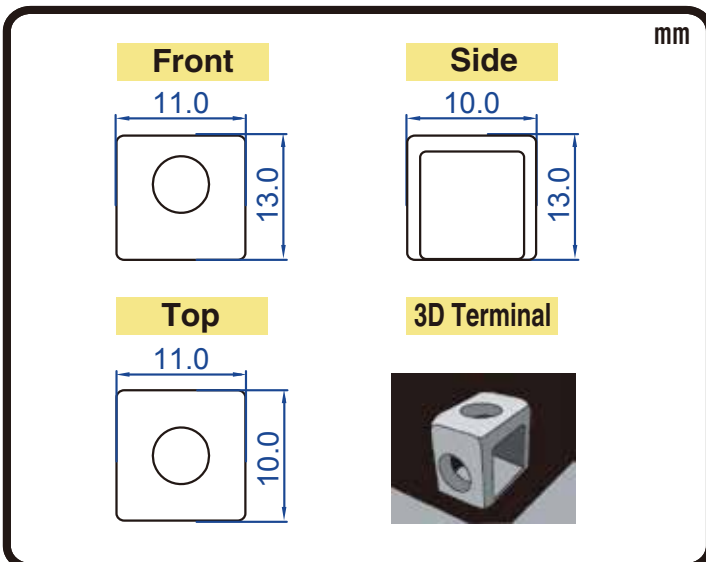

### Nut & Bolt Hardware Kits

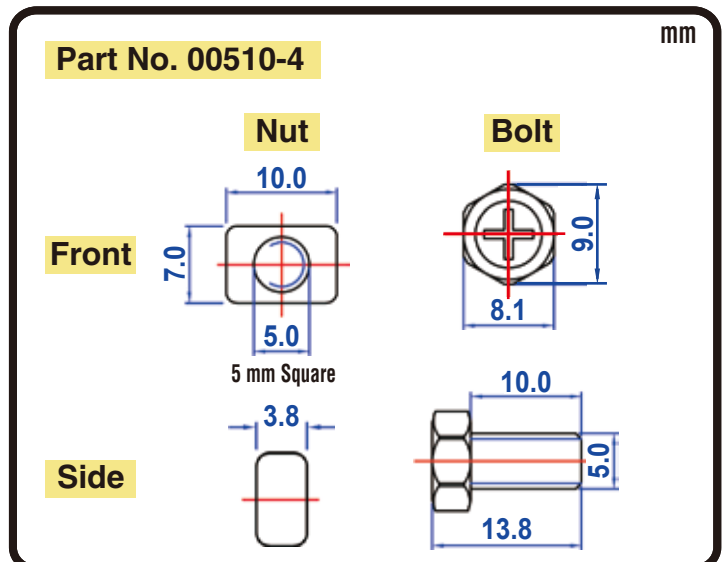

#### CORPORATE HEADQUARTERS (TAICHUNG, TAIWAN)

4F-5, No. 925, Sec. 4, Taiwan Blvd., Taichung, 40767 Taiwan, R.O.C.  
 Tel : 886-4-2358-0578 Fax : 886-4-2358-0059  
 sales@yacht-battery.com

#### YACHT BATTERY USA, INC.

Tel : 1-610-689-0443 Fax : 1-888-373-6466  
 Dave.Beidler@yacht-battery.com  
 Bruce.Ash@yacht-battery.com